

Sep.1.2017 Copyright 2017 HIROSE ELECTRIC CO., LTD. All Rights Reserved.

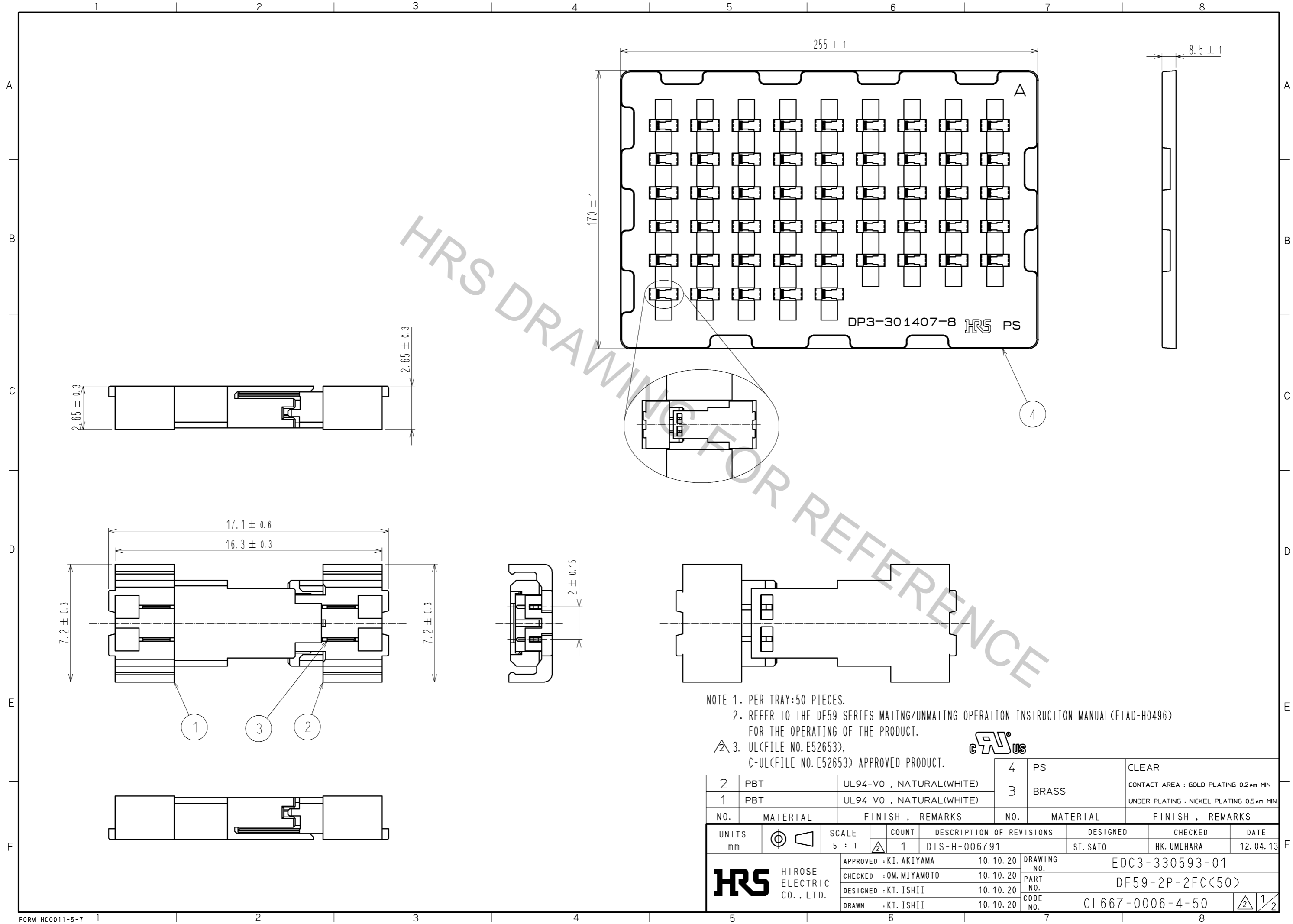

NOTE 1. PER TRAY:50 PIECES.  
 2. REFER TO THE DF59 SERIES MATING/UNMATING OPERATION INSTRUCTION MANUAL(ETAD-H0496) FOR THE OPERATING OF THE PRODUCT.  
 3. UL(FILE NO. E52653),  
 C-UL(FILE NO. E52653) APPROVED PRODUCT.

2	PBT	UL94-V0 , NATURAL(WHITE)	4	PS	CLEAR			
1	PBT	UL94-V0 , NATURAL(WHITE)	3	BRASS	CONTACT AREA : GOLD PLATING 0.2μm MIN UNDER PLATING : NICKEL PLATING 0.5μm MIN			
NO.	MATERIAL	FINISH , REMARKS	NO.	MATERIAL	FINISH , REMARKS			
UNITS mm			SCALE 5 : 1	COUNT 1	DESCRIPTION OF REVISIONS DIS-H-006791	DESIGNED ST. SATO	CHECKED HK. UMEHARA	DATE 12. 04. 13
		HIROSE ELECTRIC CO., LTD.	APPROVED : KI. AKIYAMA	10. 10. 20	DRAWING NO. EDC3-330593-01			
			CHECKED : OM. MIYAMOTO	10. 10. 20	PART NO. DF59-2P-2FC(50)			
			DESIGNED : KT. ISHII	10. 10. 20	CODE NO. CL667-0006-4-50			
			DRAWN : KT. ISHII	10. 10. 20				

# Operation Procedures for Floating Socket

## 【 Mating 】

1. Hold part A on the floating socket, and place it on the receptacle so that part A matches to part B.

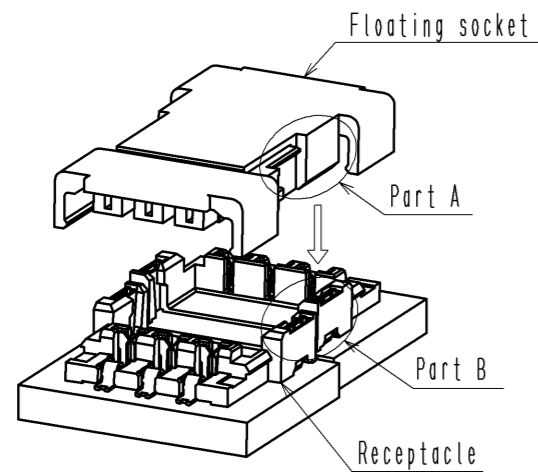

2. Align the floating socket edge on the side of friction lock to receptacle housing edge in a line.  
(Forcible mating without above alignment process could cause contact deformation.)

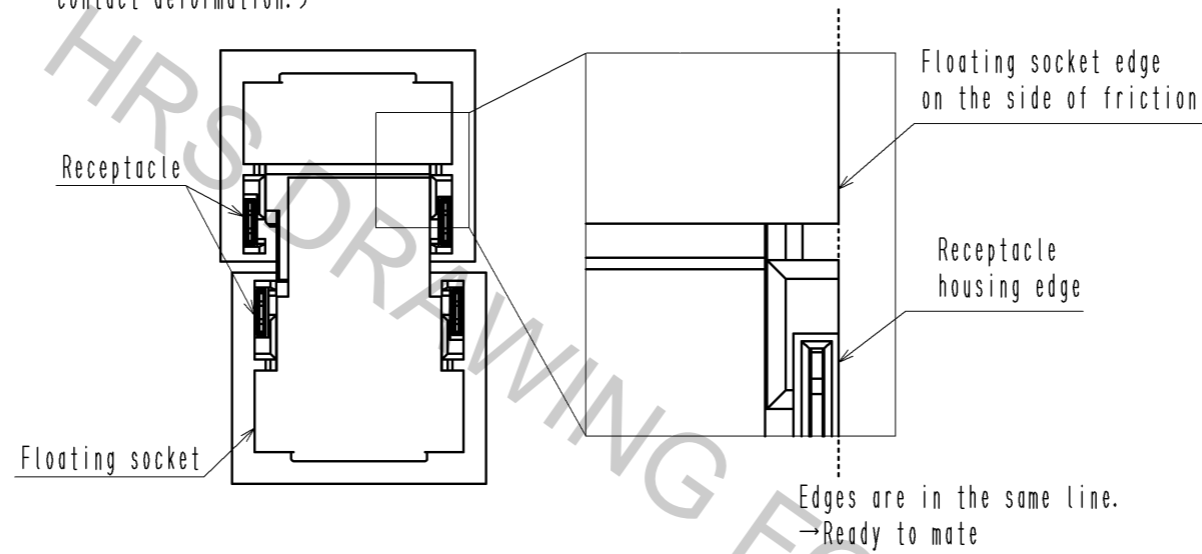

3. Press down at the center surface of the floating socket.  
(Press down until the floating socket touches to the receptacle.)

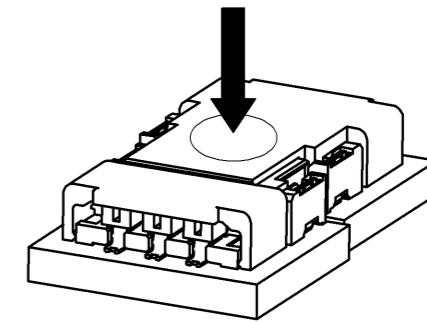

## 【 Unmating 】

1. Hook the lever on either sides of socket with finger and lift up to the upper direction for unlock.  
(Lift up until friction lock is released.)

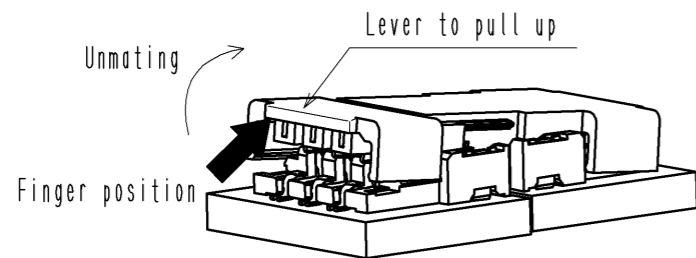

2. After releasing either side, hook the lever on the other side with a finger and lift up to the upper direction, too.

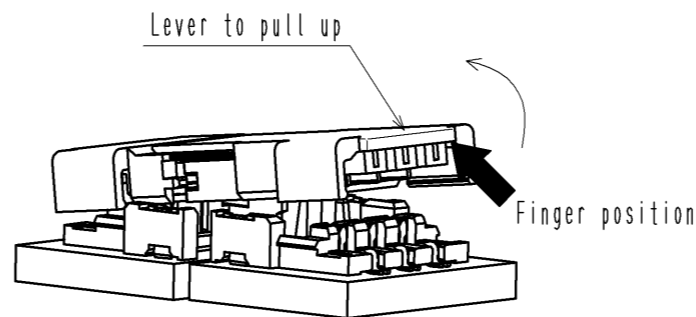

**HRS**

図番: EDC3-330593-01  
製品名: DF59-2P-2FC(50)  
製品コード: CL667-0006-4-50

2/2